

Legend

- 1) FORD VAN CHASSIS
- 2) CBCT SYSTEM
- 3) COMPUTER
- 4) GENERATOR
- 5) RUNNING BOARD (2)
- 6) 18" x 12" PANTRY CABINET
- 7) WORK SURFACE
- 8) COVERED RACEWAY (2)
- 9) WHEEL WELL COVER (2)
- 10) LED TRACK LIGHTENING w/ DIMMER
- 11) DRIVER'S SEAT
- 12) PASSENGER'S SEAT
- 13) HYDRAULIC PUMP
- 14) LEVELING SYSTEM CONTROLS
- 15) LEVELING JACKS (4) (not shown)
- 16) BACK-UP CAMERA
- 17) BUMPER
- 18) RAISED ROOF
- 19) STOOL
- 20) LEADED GLASS
- 21) SPEAKER (2)
- 22) POWER PANEL
- 23) REAR DOOR (2)
- 24) ENTRY/EXIT SLIDING DOOR
- 25) 11,000 BTU A.C. UNIT
- 26) POWERED VENT
- 27) DIVIDER WALL (2)

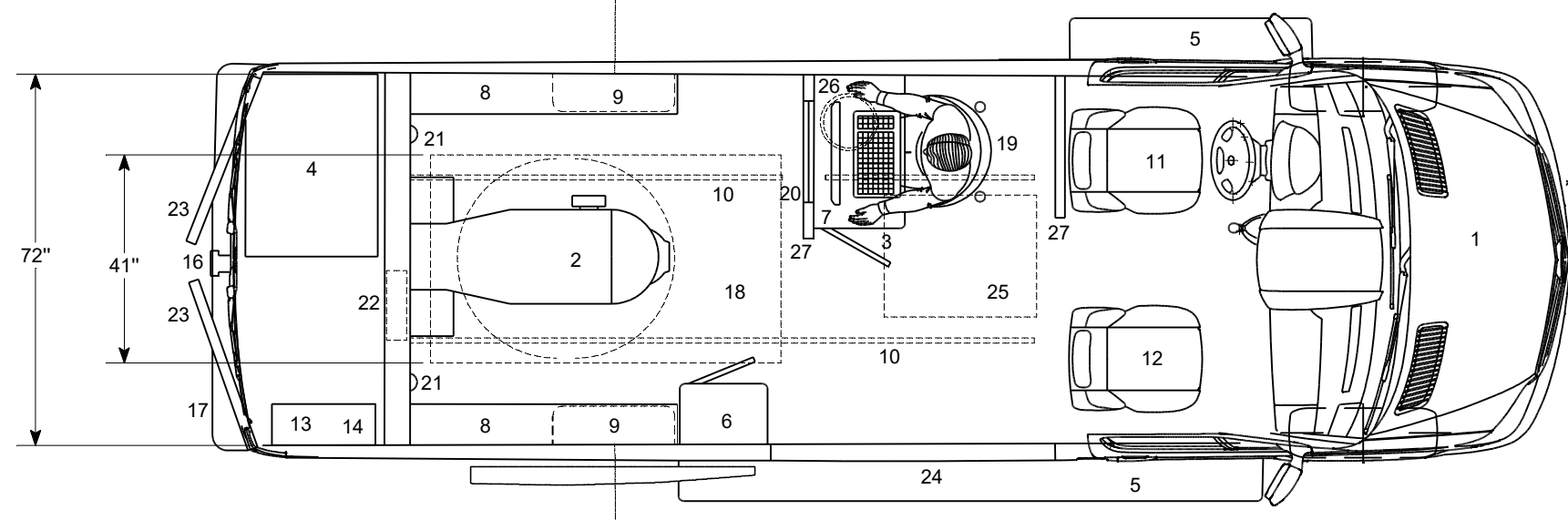
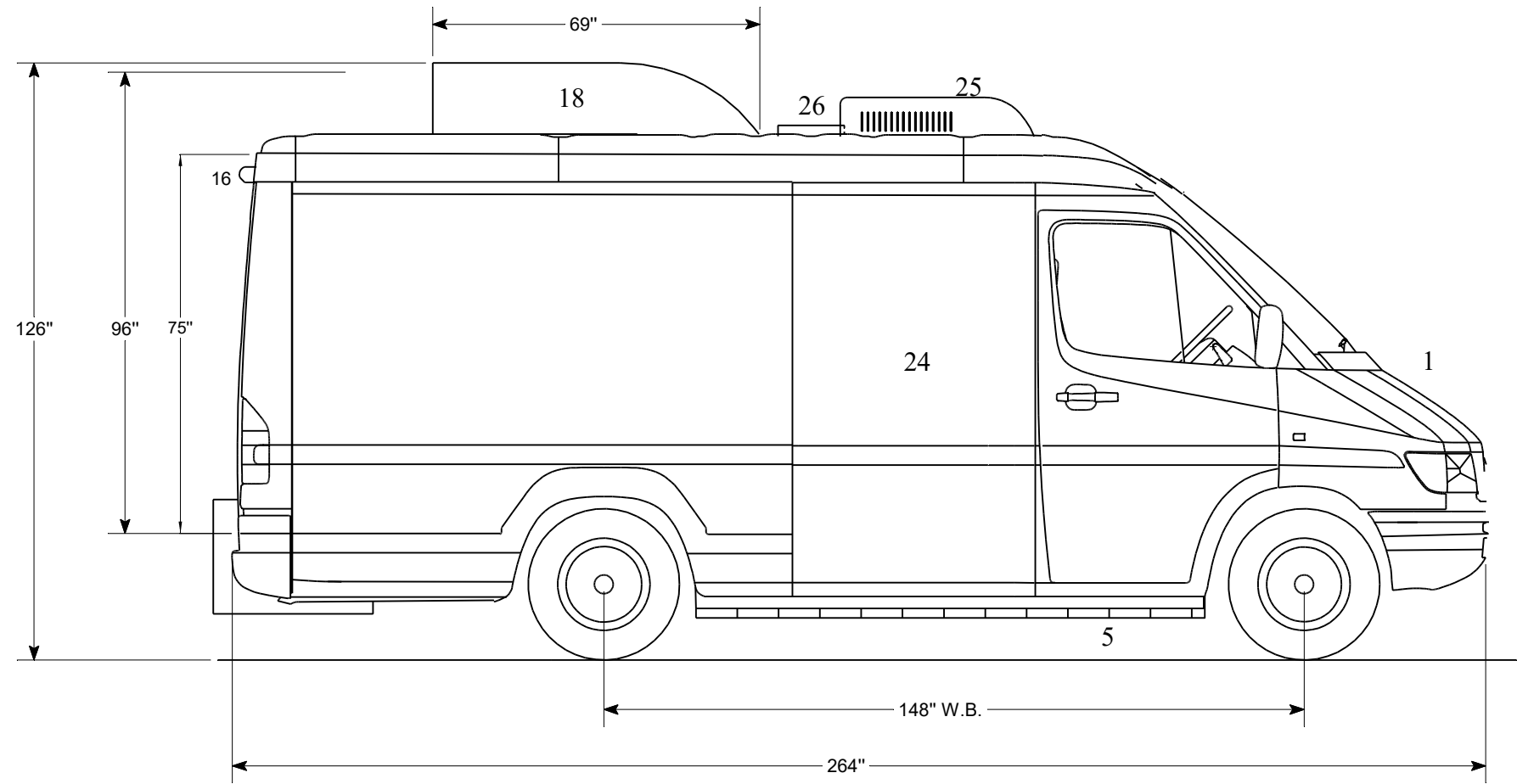

PROPRIETARY

THIS DRAWING WAS ORIGINATED BY AND IS THE EXCLUSIVE PROPERTY OF MOBILE CONVERSIONS INC. IT IS FURNISHED FOR RECIPIENT'S INFORMATION ONLY AND IS NOT AN AUTHORIZATION OR LICENSE TO MAKE THIS CONSTRUCTION OR TO FURNISH THIS TO OTHERS.

UNLESS OTHERWISE SPECIFIED: DIMENSIONS ARE IN INCHES TOLERANCES		CONTRACT NO.		MOBILE CONVERSIONS, INC. CINCINNATI, OHIO www.mobileconversions.com	
DECIMALS .XX ± .03	FRACTIONS XX/16	ANGULAR XX° ± .03	DECIMALS .XX ± .03	DRAWN BY: NICK SAMAD	DATE 10/03/2024
XXX ± .010	XX" ± .16"	XXX ± .010	---	CHECKED BY:	---
MATERIAL	MATERIAL	---	---	APPROVED BY:	---
FINISH	FINISH	---	---	FILE:	---
SIMILAR TO	SIMILAR TO	---	---	---	---
TITLE FORD TRANSIT CBCT VAN				SIZE B	CAGE CODE
SCALE: --				DWG. NO. 1001140	RELEASE DATE
SHEET 1 OF 1					